

READ ME FIRST!



D.I. Roof Seamers

4-STATION ROOF SEAMER FIELD MANUAL



Your 4-Station Roof Seamer will come packaged in this custom container. The container should not be damaged in any way. Remove the seamer from the case and visually inspect it for any type of obvious problems or damage. Along with the seamer, you will find any hand crimping tools that you may have ordered in the case. Also, there will be a field repair kit, this field manual, a certification of the roof seamer, any ordered hand tools and your shipping information.

The 4-Station Roof Seamer motor requires a 20 amp, 100-125 volt AC power supply. Poor performance and motor damage can result from use of an improper power supply.

Recommended extension cord size:

Distance (FT)	0-50	50-100	100-200	200+
Wire Gauge (AWG)	12	10	8	6

**READ THIS FIELD MANUAL COMPLETELY
BEFORE ANY SEAMING OPERATIONS!
DEATH OR SERIOUS INJURY MAY OCCUR!**

RENTER INFORMATION

- Rental Fees begin the day that you receive your seamer and end the day it is returned to our facility.
- Your rental fee is \$45 per day, Monday through Friday. You will not be charged for weekends. No credit will be issued against your rental fees for holidays or the inability to use this machine due to “natural acts” such as inclement weather.
- If you receive any tools with your seamer, they must be returned with the seamer to avoid any additional charges.
- **RETURN FREIGHT IS YOUR RESPONSIBILITY!**
- You will be billed for any damage, other than normal “wear and tear” from usage, found on the machine or hand tools.
- When complete, return the seamer to:

**D.I. Roof Seamers
915 Highway 45
Corinth, MS 38834**

- If any inconsistencies appear in the seam or if you have any questions, problems, etc... STOP SEAMING and contact Technical Support at 1-888-343-0456 immediately. Do not attempt to alter, maintenance, adjust or correct any setting on this machine without instruction from a technician.
- Follow all safety suggestions, warnings, etc... in this manual and posted on the machine itself. Failure to do so may result in serious injury or death.
- Do not attempt to ride the Roof Seamer in any way.
- For additional information, visit www.diroofseamers.com.

It is recommended to “seam as you go”. In other words, seam the roof panels as they are being installed. This ensures that each panel is kept within module and installed correctly.

If the roof has already been installed, each clip must be hand crimped with a 90° (Single Lock) Hand Crimper to keep each panel safely in place.

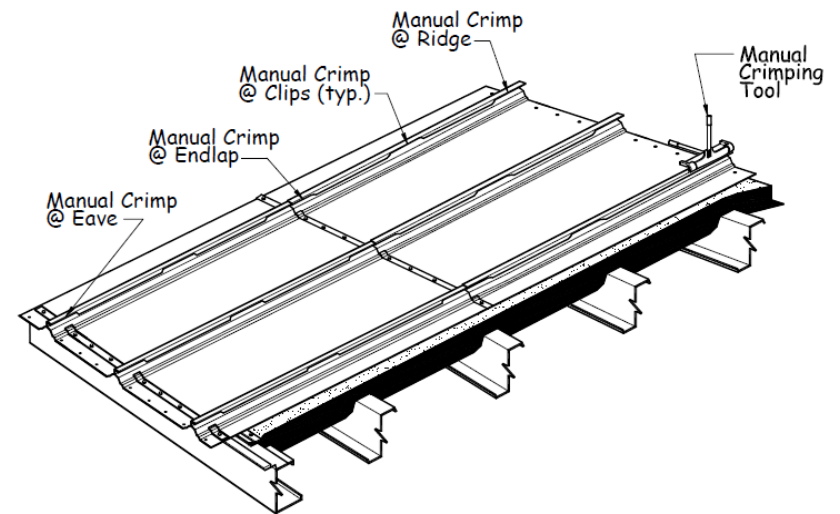

Before beginning, ensure that the panel is installed correctly and is free of all debris and contaminants such as sand, snow, excessive fluids, sealant/mastic, tools, extensions cords, etc... Also, always attach a safety hook to a tether during any time the seamer is on the roof to prevent it from falling off.

to begin, hand crimp 8"-10" of each panel at the beginning of the seam with the 90° (Single Lock) Hand Crimpers.

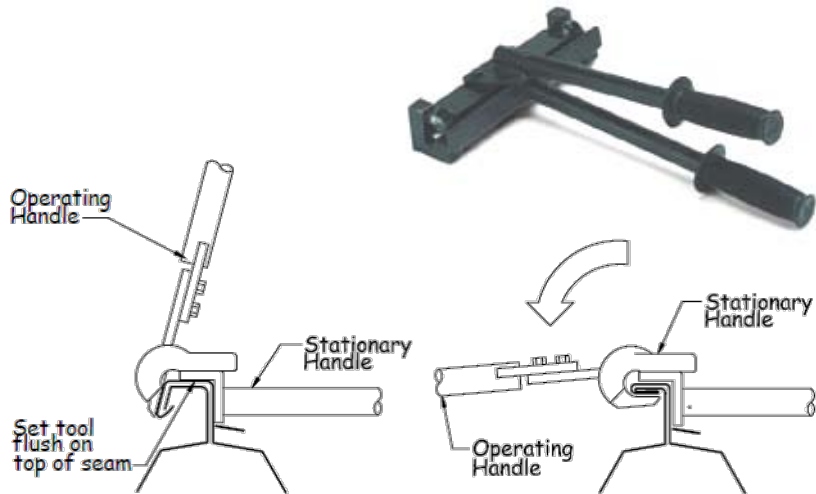

Next, hand crimp 5" at the beginning of the seam with the 180° (Double Lock) Hand Crimpers.

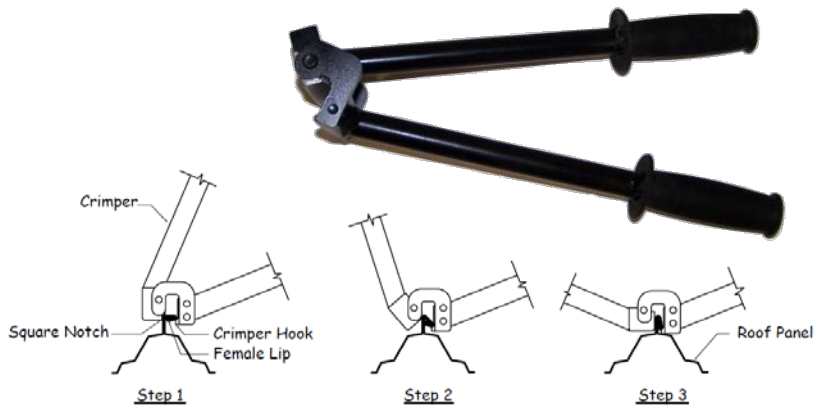

Next, place the machine on the hand crimped portion and engage each of the four locking handles by pulling the locking handles out until they lock into place. Note: Ensure that the last locking handle of the seamer is aligned over the Double Locked portion that was hand crimped. Add the power supply into the quick-release plug near the handle of the machine and turn the machine on. Run the seamer for about 12" to ensure that you are receiving the desired seaming operation. If so, continue in this manner for the completion of the run. If not, STOP SEAMING and contact Technical Support immediately.



It is important to remember to use extreme caution when reaching the edge of the roof. Stop the seamer while the wheels remain on the roof panel. Roll machine back to a safe working area before disengaging the locking handles.

Do not run the seamer within 6" of the end of a panel, beyond the end of a panel or over a previously seamed area.

Use your hand crimpers to finish any area that the seamer may not be able to complete, such as against a ridge cap, end cap or at a pitch change in the roof.

Note: The Roof Seamer may leave dark forming marks on light colored panels. This is acceptable as long as the paint finish is not damaged. Marks can easily be rubbed off by hand – DO NOT use solvents that will soften or remove paint.

Seaming Problem	Possible Cause	Look For	Recommended Fix
Roof Seamer dragging, stalling at clips, running intermittently or will not run.	Extension cord too long and/or not heavy enough gauge cord.	7+ amp at motor with NO LOAD (locking handle locked). 10+ amp at motor while seaming (between clips).	Use a shorter and/or heavier gauge extension cord.
	Generator not supplying proper amperage to Roof Seamer.	7+ amp at motor with NO LOAD (locking handle locked). 10+ amp at motor while seaming (between clips).	Use a larger generator.
	Faulty Motor.	7+ amp at motor with NO LOAD (locking handle locked). 10+ amp at motor while seaming (between clips). Motor will not run.	Contact D.I. Roof Seamers for replacement unit.
Seam hook not closed properly or improper nesting of male leg to female leg and/or clip.	Excess panel coverage width (typically 1/2"+).	Cladding or paint deposit on forming roller.	Ensure correct coverage width at installation.
	Incorrect profile of damaged (deformed) clip or male/female panel leg.	Seam does not appear to be fully engaged.	Correct the profile of the male/female panel leg. If necessary, hand crimp the corrected area.
Creasing, scuffing, etched line along top of the seam and/or deformation of seam.	Cam roller does not turn freely.	Cam roller bearing frozen or fouled by sealant or masting.	Clean and lubricate or replace cam roller.
Cladding or paint pick-off.	Incorrect profile of damaged (deformed) clip or male/female panel leg.	Seam does not appear to be fully engaged.	Correct the profile of the male/female panel leg. If necessary, hand crimp the corrected area.
	Excess panel coverage width (typically 1/2"+).	Cladding or paint deposit on forming roller.	Ensure correct coverage width at installation.

In the event of any problem, contact Technical Support at

1-888-343-0456

Monday – Friday 8:00am – 5:00pm CST

Copyright ©2009 Developmental Industries, Inc.